

Reg. No. :

Question Paper Code : 20628

B.E./B.Tech. DEGREE EXAMINATION, NOVEMBER/DECEMBER 2018.

First Semester

Mechanical Engineering

GE 6152 — ENGINEERING GRAPHICS

(Common to All Branches)

(Regulations 2013)

Time : Three hours

Maximum : 100 marks

Missing data, if any, may be suitably assumed and stated clearly.

Answer ALL questions.

(5 × 20 = 100)

1. (a) Draw the front view, top view, and right side view of the pictorial view of the object shown in Fig. 1 (a), and indicate the relevant dimensions:

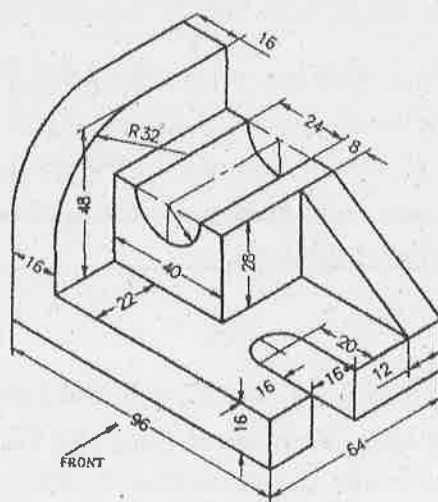

(All dimensions are in mm)

Fig. 1 (a)

Or

- (b) The end point of a cable wire is unwinding itself from a drum of 750 mm diameter, such that the unwound cable wire is always taut. Draw the locus of the end point of the cable wire using a scale of 1:20, and name the drawn curve. Also, draw the tangent and the normal at any point of your choice on the curve.
2. (a) A line AB 90 mm long has its end A 15 mm above the HP and 20 mm in front of the VP. The other end B is 75 mm above the HP and 65 mm in front of the VP. Draw the projections of the line and find the true and apparent inclinations with both HP and VP. Also, find the lengths of the top view and front view. Locate and show the traces.

Or

- (b) A regular pentagonal lamina of 30 mm side rests on HP on one of its sides such that the surface of the lamina makes an angle of 45° with HP. Draw its projections when the side on HP makes an angle of 30° with VP.
3. (a) A cone of base diameter 40 mm and axis 65 mm long, is resting on HP on a point of its base circle, with the axis making an angle of 45° with HP and its top view making an angle of 35° with VP. Draw the projections of the cone.

Or

- (b) A square pyramid of side 30 mm and axis 60 mm long has one of its slant edges inclined at 45° to HP and a plane containing that slant edge and axis is inclined at 40° to VP. Draw the projections of this square pyramid.
4. (a) A pentagonal prism of 30 mm base side and height 50 mm is standing on HP on its base, with one side of base perpendicular to VP. This prism is cut by a section plane 40° inclined to HP through mid-point of the axis. Draw the front view, sectional top View, and sectional side view. Draw, also, the true shape of the section.

Or

- (b) A hexagonal prism of base side 25 mm and height 55 mm, rests with its base on HP such that one of its rectangular faces is parallel to VP. This prism is cut by a plane perpendicular to VP, inclined at 45° to HP and passing through the right corner of the top face of the prism. Draw the sectional top view and the development of lateral surface of the truncated prism.

5. (a) A frustum of a cone with base diameter 45 mm and top diameter 30 mm is centrally placed over a hexagonal prism of base side of 35 mm and height 40 mm. The height of the cone frustum is 50 mm. Draw the isometric view of the combined structure.

Or

- (b) A rectangular prism with sides of base 50 mm \times 35 mm and height 60 mm, rests with its base on the ground plane. A vertical edge is in the picture plane and one of the longer edges of its base is inclined at 40° to picture plane (PP), and behind it. The station point is 50 mm in front of PP, 75 mm above the ground plane and lies in a central plane which passes through the centre of the prism. Draw the perspective projection of the rectangular prism.

